

## TECHNICAL DATA SHEET FOR E35

### Full Size Electric Convection Oven

#### E35 OVEN

- 6 sheet pan capacity (8 with cookie kit option)
- Stainless steel outer
- Porcelain inner
- Solid state thermostat
- \* Plug in door seal
- 60 minute bake timer
- Hot reversing air system
- Time driven steam system
- 2 speed fan
- Field reversible door



E35

---

E35 Unit shall be a Moffat electrically heated Turbofan convection oven, E.T.L listed (UL Std 197, NSF-4). The oven shall have a one piece vitreous porcelain enamel oven liner, stainless steel exterior, twin pane field reversible full view glass door with ventilation top and bottom, with the outer panel hinged for cleaning. A two speed auto reversing fan shall evenly circulate air internally. Heating shall be accomplished via electric elements surrounding the fan. The oven shall be controlled by a solid state thermostat accurate to  $\pm 2^{\circ}\text{F}$ , range  $150^{\circ}\text{F}$  to  $550^{\circ}\text{F}$ , have a 60 minute bake timer, push button steam injection system, fan speed control and oven vent control. Oven shall be able to be bench mounted on 4" legs or on Moffat's A26 stand or E85-HLD proofer and holding cabinet, rated for zero clearance left and rear.

## E35 Full Size Electric Convection Oven

### CONSTRUCTION

Tops and sides stainless steel  
 Porcelain oven interior  
 Stay cool twin pane glass door (outer surface)  
 163°F when oven operating at 356°F  
 Interlocking door handle  
 Stainless steel oven racking system with runners for wire racks or full size sheet pan  
 Insulated all round for zero clearance left side and rear  
 Porcelain control panel  
 Field reversible door

### CONTROLS

Electronic thermostat variable from 150°F to 550°F ± 2°F  
 1 hour bake timer with buzzer  
 Timed water injected steam  
 2 speed fan (700rpm-1400rpm)  
 On/off switch  
 Hot reversing air system  
 High limit safety

### CLEANING

Stainless steel top and side exterior panels side of the unit  
 Easy clean surfaces  
 Fully removable oven racking system  
 Door outer glass hinged for cleaning access  
 Removable Proofer water tank

### OPTIONS

Fully insulated stainless steel door with twin pane glass viewing window  
 E85-A-8-HLD or E85-A-12-HLD Proofers and Holding Cabinets  
 Sheet pans, wire racks  
 Specialist side racks for cookies

### SPECIFICATIONS

#### Electrical Requirements

208V 3ph+E 11.2kW L1 31.1A  
 L2 31.1A  
 L3 31.1A  
 220-240V 3ph+E 12.5kW L1 30-1A  
 L2 30-1A  
 L3 30-1A

#### Water Requirements

¾" thread  
 80psi maximum inlet pressure  
 20psi minimum inlet pressure

#### External Dimensions

Width 34½" / 880mm  
 Height 31½" / 800mm  
 Depth 34½" / 880mm

#### Internal Dimensions

Width 18" / 460mm  
 Height 28" / 710mm  
 Depth 26" / 660mm

#### Oven Rack Dimensions

Width 18" / 460mm  
 Depth 26" / 660mm

#### Nett Weight

330lbs / 150kg

#### Packing Data

441lbs / 181kg  
 33.8ft³ / 0.96m³  
 Width 39½" / 1001mm  
 Height 39" / 990mm  
 Depth 38" / 965mm

#### INSTALLATION CLEARANCES

Rear 0" / 0mm  
 LH Side 0" / 0mm  
 RH Side 3" / 75mm

\* For fixed installations a minimum of 20" / 500mm is required for service

#### CLEARANCE FROM SOURCES OF HEAT

A minimum distance of 12" / 300mm from the appliance sides is required

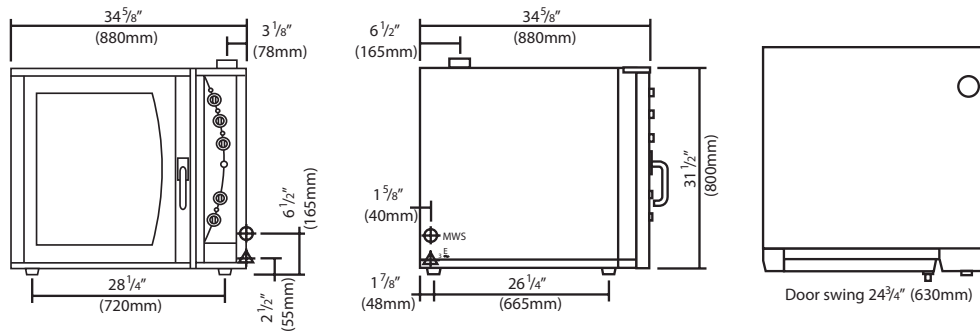

## MOFFAT®

www.moffat.com

U.S.A.

Moffat Inc  
 3765 Champion Boulevard  
 Winston-Salem  
 North Carolina 27105  
 Ph Toll Free 1-800-551 8795  
 Ph 336-661 0257  
 Fax 336-661 9546  
 Email sales@moffat.com  
 www.moffat.com

Manufactured by:

Moffat Limited  
 16 Osborne Street PO Box 10-001  
 Christchurch 8081 New Zealand



ISO9001  
 Quality  
 Management  
 Standard

Designed and manufactured by

**MOFFAT®**

ISO9001

All Turbofan products are designed and manufactured by Moffat using the internationally recognised ISO9001 quality management system, covering design, manufacture and final inspection, ensuring consistent high quality at all times.

In line with policy to continually develop and improve its products, Moffat Limited reserves the right to change specifications and design without notice.



© Copyright Moffat Ltd  
 Moffat 1270 / 3.12

